



**Auto-Spreader Spreader™ HS10K  
Hydraulic Flange Spreader**

*US Patent No. 5678293*

**Operation and Maintenance Manual**

Keep For Your Records

## Contents

Operation.....	2
Maximum Spreader Extension.....	3
Safety Tips.....	4
Maintenance.....	5
Foot Replacement Instructions.....	5
Tool Storage.....	6
Parts List.....	7
Disassembly Instructions.....	10
Assembly Instructions.....	11
Trouble Shooting.....	13
Limited Warranty.....	14

## Figure Index

Fig. 1	Flange Spreading.....	3
Fig. 2	Maximum Spreader Extension.....	4
Fig. 3	Safety Block.....	4
Fig. 4	Safety Blocks on Flange.....	5
Fig. 5	Storage/Ready Position.....	6
Fig. 6	Exploded View.....	8
Fig. 7	Center Foot Assembly.....	11

## Operation

**Important:** Do not operate the tool before reading these instructions

The Auto-Spreader™ HS10K is designed for spreading and lifting. It is a small, light and powerful precision tool. It generates 10,000 lbs. of spreading force by using hydraulic power. It is extremely versatile, and can be used wherever lifting power is needed.

Some Common Applications:

- Flange Spreading
- Controlled Lift, Level, and Align Heavy Equipment
- Shaft Replacement
- Impeller Replacement
- Separate Manways
- Change Gaskets, Turn Blinds
- Hydraulic Model Allows for Remote Opening of Flanges

The Auto-Spreader is simple to use. To spread the feet, connect the hydraulic cylinder to a hydraulic pump and pressurize it. To close the feet, release the pressure of the pump. The cylinder has a spring return.

The Auto-Spreader only needs .09" or 2.3 mm gap to engage the feet. It has a separating capacity of 3" spread under full load. The high strength alloy steel forged feet close automatically when the pressure is released.

Note: When using the Auto-Spreader for flange spreading, it is recommended that two Auto-Spreaders be used. Place the flange spreaders on opposite sides of the flange for even spreading. See figure 1.

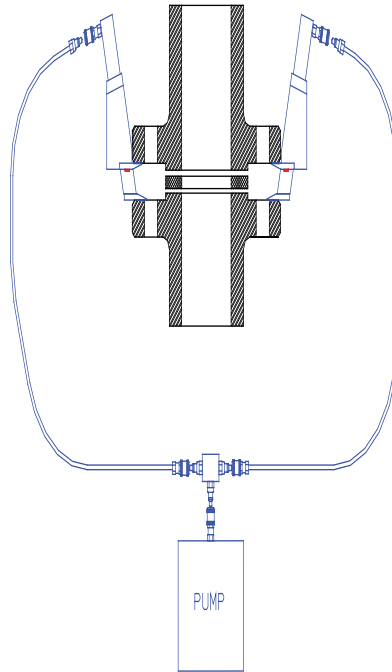

Figure 1

### Maximum Spreader Extension

A red mark will appear on the shaft of the center foot, when maximum safe extension is achieved. See figure 2.

***Creating pressure beyond the 10,000 PSI rated capacity may result in injury.***

Figure 2

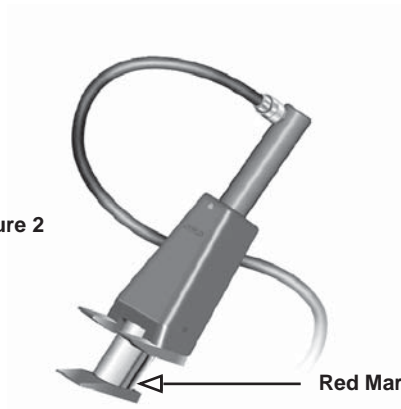

### Safety Tips

- Always wear the appropriate protective equipment, such as safety glasses and gloves.
- Always use safety blocks under any load being lifted with the tool, where possible. See figures 3 & 4.
- Never place any body part between the tool and the equipment being worked on.
- Creating pressure beyond the 10,000 psi rated capacity may result in injury.

### Safety Block Benefits

- Multi-Step Design: Each safety block has three steps - 1", 2", & 3", which allows the operator to choose the width of flange separation.
- Light Weight with Easy Grip Handle: Allows the operator to easily grip the safety block, even when wearing gloves.
- Secure Support: After the Auto-Spreader opens the flange, safety blocks are inserted in the gap between the flanges. The flange spreaders are then closed to transfer the load to the safety blocks, enabling the operator to work more safely on the gasket surfaces.



Figure 3

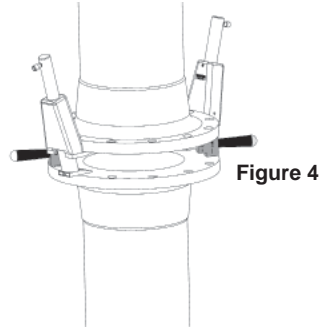

**Safety Blocks on Flange**

### **Maintenance**

Treat the Auto-Spreader like any other precision tool. Keep it clean and free from moisture. Simply wipe it down with a cloth or paper towel after use.

If there is damage, due to improper storage or unusual circumstances, contact Fastorq for handling instructions.

All internal parts are lubricated at the factory and do not need cleaning or re-lubrication.

All the materials used in the Auto-Spreader were chosen through extensive research. All parts are rated for their intended use, and do not need field repair. Improper assembly, modification or substitution of other parts is unsafe, will void the warranty and could damage the tool.

### **Foot Replacement Kit**

After extended usage, the feet may need replacement. These are the only parts which are field replaceable. Call 1-800-231-1075 for the Auto-Spreader foot replacement kit, refer to part #RKCF for the center foot kit or part #RKOF for the outside feet kit.

## Foot Replacement

When it is necessary to replace a foot on the Auto-Spreader follow these steps:

1. Close the feet. The center foot (6) should be aligned with the outside feet (2 and 3). See figures 5 and 6.
2. Loosen the two flat head Allen screws (1,4) on the bottom of the foot being replaced.
3. Remove old foot and position new foot in its place.
4. Tighten the two flat head Allen screws.

Note: It is very important that the flat head Allen screw be properly tightened. The required torque value is 40 ft. lbs.

## Tool Storage

1. Wipe the tool clean with a cloth or paper towel.
2. Close the feet.

Note: The Auto-Spreader should be kept in the ready position when not in use; feet closed. See figure 5.

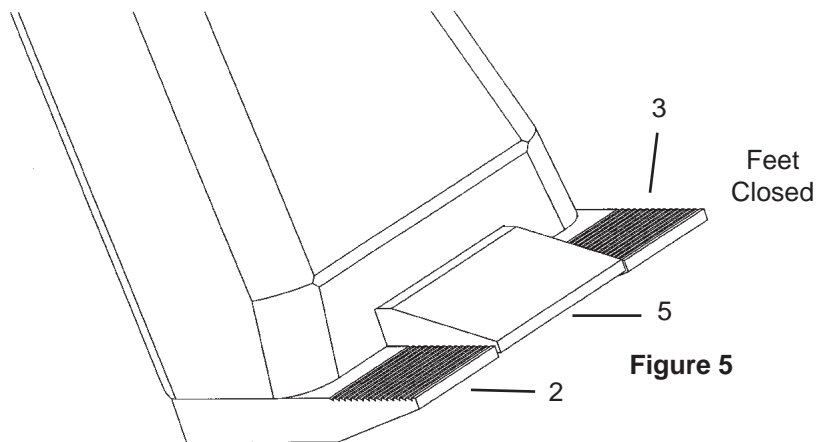

## Parts List

<u>Item</u>	<u>Part #</u>	<u>Description</u>	<u>Qty</u>
1	FHCS08-13x20	1/2"-13 Flat Head Allen Bolt	4
2	A95055L	Left Jaw	1
3	A95055R	Right Jaw	1
4	FHCS07-14X16	7/16"-14 Flat Head Allen Bolt	2
5	A95050	Center Jaw	1
6	B99050	Piston	1
7	DP04X20PO	Dowel Pin	1
8	D98175	Housing	1
9	SS05-18X08SS	5/16" Stainless Set Screw 1/2" Lg.	1
10	A97101	HS10K Adapter	1
11	C-5	5-Ton Cylinder	1
12	SK10K-SB	Safety Block	1
13	55TB	Tool Box (not shown)	1
14	HS10K-TBI	Tool Box Insert (not shown)	1

Refer to figure 6, an exploded view of the spreader for corresponding item numbers.

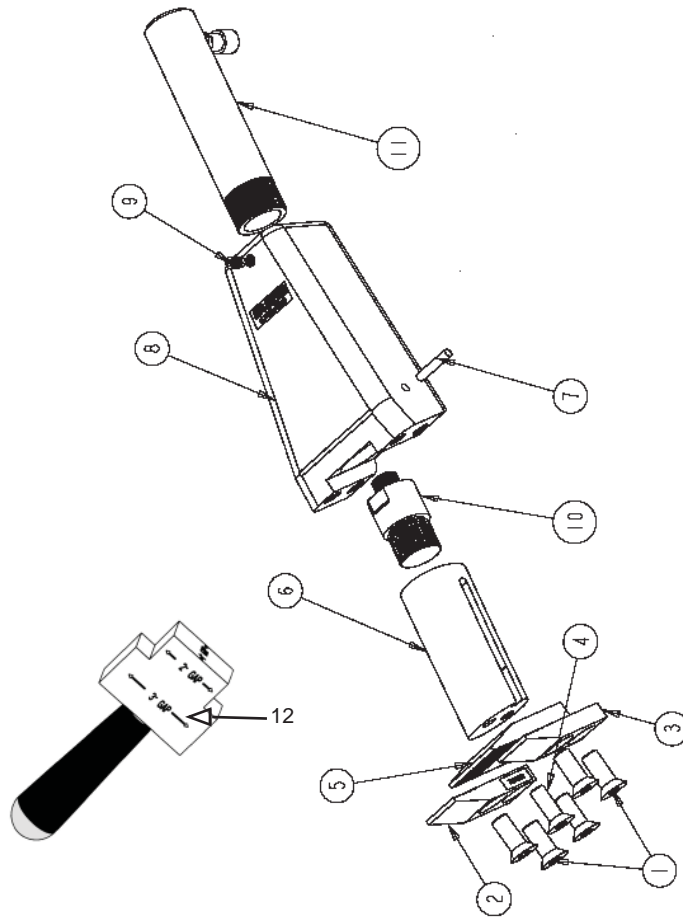

Figure 6

**Auto-Spreader HS10K  
Hydraulic Flange Spreader**

### **Assembly/Disassembly Instructions**

The Auto-Spreader™ HS10K is delivered assembled and ready to use. If it is necessary to disassemble the Auto-Spreader for repairs, follow the assembly instructions carefully when re-assembling. Failure to follow these instructions may damage one or more of the components. If any of the Auto-Spreader components are damaged, please contact your Fastorq representative before re-assembly.

### **Disassembly Instructions**

All numbers in parentheses are referenced in figure 6 and the Parts List on page 7.

Should it become necessary to disassemble the Auto-Spreader, follow these steps:

Note: Before disassembling the tool, mark the position of the cylinder in reference to the housing.

1. Close the feet by retracting the center foot until it is aligned with the outside feet.
2. Position the Auto-Spreader on its side. The side with the dowel pin (7 ) should be facing up.
3. Insert a socket head cap screw or any hardened screw with #8-32 threads and about 2" long in the hole and screw it in the dowel pin inside the hole.

4. Engage the screw using a pry bar and pull it out 1/2". The dowel pin should come out along with the screw.
5. Extend the cylinder to the maximum extension mark on the piston (6).
6. Pressurize the cylinder to 2,000 PSI or so.
7. Turn the sub-assembly counter-clockwise until it is completely unscrewed and slides out easily. The sub-assembly consists of the adapter (10), piston (5) and the center foot (7).
8. Release the pressure to retract the cylinder and disconnect the cylinder from the pump.
9. Loosen the set screw in the front of the housing with a 5/36" Allen wrench. Remove the cylinder (11) by turning it counter-clockwise.

### **Assembly Instructions**

1. Review the Parts List and verify that all the parts are available and in good order.
2. Clean all the parts with a de-greasing solvent.
3. Screw the cylinder (11) all the way onto the housing (8).
4. Position the outside feet (2 and 3) against the bottom of the housing (8). Be sure to place the feet, which are marked (L) and (R), on the appropriate sides of the housing. The countersunk screw holes should be facing out, and not against the bottom of the housing (8).
5. Insert the flat head Allen screws (1) in the screw holes on the outside feet, and tighten them with a 5/16" Allen wrench to 35-40 Ft lis.
6. Place the center foot (5) on top of the piston. The countersunk screw holes will be facing up. See figure 7.

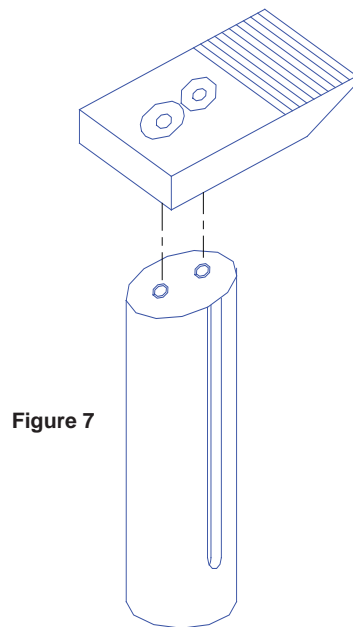

Figure 7

7. Insert the flat head Allen screws (4) in the screw holes on the center foot, and tighten them with a 1/4" Allen wrench to 25-30 ft. lbs.

8. Screw the adapter (10) into the piston (6) all the way until the shoulder on the adapter touches the top of the piston. Torque to approximately 35 ft. lbs. Note: The adapter has left hand threads.

9. Lightly lubricate the outside of the piston (6) with Fastorq A/G (70% solid lubricant), which can be purchased from Fastorq.

10. Connect the hydraulic cylinder to a pump through the quick disconnect attached to the cylinder. Use 10,000 PSI W.P. rated hydraulic hose. Extend the cylinder by pressurizing the pump. Maintain full pressure on the cylinder while executing step 11.

11. Insert the sub-assembly in the housing (8). The sub-assembly consists of the center foot (5), piston (6), adapter (10). Screw the assembly clockwise into the front of the piston rod, until the adapter stops against the cylinder rod.

12. Release the hydraulic pressure from the cylinder and the center foot will retract.

13. Install the dowel pin (7) in the hole on the side of the housing (8), use a hammer if necessary. The dowel pin will ride in the slot on the side of the piston (6), if everything is properly assembled.

14. Check the feet again to be sure they are still aligned. Check the alignment of the cylinder in reference to the housing (this should have been marked in disassembly). Insert the set screw (9) in the hole provided in the front of the housing (8). Tighten the set screw to the cylinder. Do not tighten the set screw too tight, or future removal of the cylinder may be difficult.

15. Pressurize and de-pressurize the cylinder to check that the tool is operating properly.

## **Trouble Shooting**

General Notes:

- Do not twist or bend hoses too sharply.
- Pay close attention to keeping all parts clean internally and externally. (Dirt and foreign matter are the most common causes of trouble in hydraulic systems)
- Make sure all quick couplers are always completely coupled together.

## Trouble Shooting Table

Problem	Possible Causes	Possible Solutions
Cylinder won't cycle in and out	<ol style="list-style-type: none"> <li>1. Insufficient hydraulic pressure and flow</li> <li>2. Quick disconnect not completely engaged</li> </ol>	<ol style="list-style-type: none"> <li>1. Check for sufficient supply of hydraulic oil</li> <li>2. Check the quick disconnects-they must be fully engaged and in good repair. Check the pump.</li> <li>3. When using pneumatic pumps, check that there is sufficient air pressure and check the air supply hose.</li> </ol>
Dirt or contaminated oil circulating in the system	<ol style="list-style-type: none"> <li>1. External or internal parts are not clean.</li> <li>2. Dirty Filter</li> </ol>	<ol style="list-style-type: none"> <li>1. Change the oil and clean the pump</li> <li>2. Check the internal filter</li> </ol>
Oil Level Low	<ol style="list-style-type: none"> <li>1. Leaking pump, hose or filter</li> </ol>	<ol style="list-style-type: none"> <li>1. Check the oil level and refill to proper level</li> <li>2. Replace hoses and/or gaskets</li> </ol>
Air in system	<ol style="list-style-type: none"> <li>1. Improperly purged hoses</li> </ol>	<ol style="list-style-type: none"> <li>1. Bleed system and check for cause of air in system</li> </ol>
Piston will not return	<ol style="list-style-type: none"> <li>1. Damaged piston rod.</li> <li>2. Improper connections</li> <li>3. Broken return spring</li> </ol>	<ol style="list-style-type: none"> <li>1. Check for obstructions around rod</li> <li>2. Check quick disconnects to make sure they are fully engaged</li> <li>3. Replace spring</li> </ol>
Ram leaks around piston rod	<ol style="list-style-type: none"> <li>1. Worn seals</li> </ol>	<ol style="list-style-type: none"> <li>1. Replace seals</li> </ol>

### **Limited Warranty**

Fastorq warrants its products against defect in workmanship and materials for 180 days from date of delivery to customer.

Warranty does not cover ordinary wear and tear, abuse, misuse, overloading or altered products.

# **FASTORQ®**



Office: 281.449.6466  
Toll Free: 1.800.231.1075  
Fax: 281.572.1329  
Email: [sales@fastorq.com](mailto:sales@fastorq.com)  
Web: [www.fastorq.com](http://www.fastorq.com)  
Mail: P.O. Box 60869 AMF  
Houston, TX 77205-0869