

**FASTORQ<sup>®</sup>**  
**Auto-Torq<sup>™</sup>**  
**THINLINE WRENCH**  
**SERIES 150-4**

Operation & Maintenance Manual



KEEP FOR YOUR RECORDS

[www.fastorq.com](http://www.fastorq.com)

## Contents

Unpacking . . . . .	3
Introduction . . . . .	3
Safety Tips . . . . .	4
Power Requirements . . . . .	5
Parts List . . . . .	6 - 7
Assembly	
Section 1 - Standard Flanges . . . . .	8 - 9
Section 2 - Non-Standard Flanges . . . . .	10 - 12
Operation	
Tightening . . . . .	13 - 14
Loosening . . . . .	14 - 15
Troubleshooting . . . . .	18
Storage . . . . .	18
Auto-Torq™ Thinline Wrench Models . . . . .	19
Limited Warranty . . . . .	Back Cover

## Unpacking

The Auto-Torq Thinline wrench is fully tested before it is shipped. Upon receiving your wrench, verify that you have received the following items (see *Figure 1*):

- \*Semi-Ratchet wrench head (1)
- \*Reaction plate (2)
- \*Reaction leg (3)
- \*Hydraulic cylinder (4)
- \*Bolt (5)

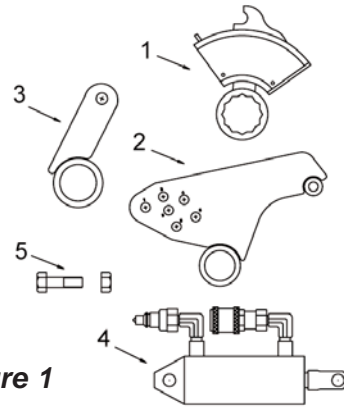

**Figure 1**

## Introduction

You have chosen the finest hydraulic torque wrench on the market.

Auto-Torq™ Thinline wrenches are dependable and durable. When operated properly, these wrenches deliver accurate torque output within their specified range.

Read this manual carefully.

For additional information call FASTORQ® at 281-449-6466 Or 800-231-1075.

Auto-Torq™ Thinline wrenches apply torque as the cylinder is extending. *Figure 2* shows the wrench in operation.

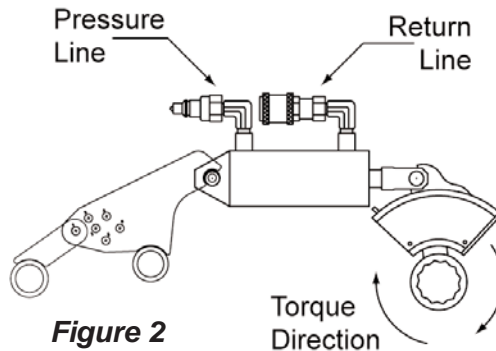

**Figure 2**

## Safety Tips

- > Always wear the appropriate safety equipment when operating this wrench; such as safety goggles or safety glasses and protective gloves.
- > Do not allow the hydraulic hose to kink, twist, curl or bend so tightly that the oil flow within the hose is blocked or reduced. Never attempt to grasp a pressurized leaking hose with your hands.
- > Never exceed the rated pressure of the wrench.
- > Do not place your hands between the wrench and the reaction point.
- > Use the torque values specified by your equipment manufacturer whenever it is available. For your convenience a chart of torque values for common size studs is included (*page 17*). This chart should not be used for any other type of stud as improper loading of the studs may cause damage to your equipment.
- > Read and follow all instructions to avoid the risk of personal injury and/or property damage.

## Power Requirements

Auto-Torq™ Thinline wrenches are hydraulically driven. They require a hydraulic pump unit that can deliver at least 5,500 psi of hydraulic pressure.

The hydraulic pump can be driven by an air motor or an electric motor.

FASTORQ carries a wide range of power pumps that can be used with Thinline wrenches. See *Table 1* below.

<b>Model Number</b>	<b>Motor Type</b>	<b>Maximum Operating Pressure</b>
605A	Air	6,000 psi
205A	Air	10,000 psi
210E	Electric	10,000 psi
215E	Electric	10,000 psi

***Table 1***

FASTORQ power units include the necessary fittings and hoses.

For complete information on these units, contact FASTORQ at 281-449-6466 OR 800-231-1075.

Parts List - Series 150-4 Reaction Units		
Item#	Part#	Description
<b>TLH104-4</b>		
1	TLH104-4P	TLH104-4 Reaction Plate
2	TLH104-4L	TLH104-4 Reaction Leg
3	HHCS8-20-GR8	Hex Bolt, 1/2" x 1-1/4" Long Grade 8
4	NT8-SS	1/2" Nut, S.S.
5	TLH104-4H	TLH104-4 Wrench Head
<b>TLH107-4</b>		
1	TLH107-4P	TLH107-4 Reaction Plate
2	TLH107-4L	TLH107-4 Reaction Leg
3	HHCS8-20-GR8	Hex Bolt, 1/2" x 1-1/4" Long Grade 8
4	NT8-SS	1/2" Nut, S.S.
5	TLH107-4H	TLH107-4 Wrench Head
<b>TLH110-4</b>		
1	TLH110-4P	TLH110-4 Reaction Plate
2	TLH110-4L	TLH110-4 Reaction Leg
3	HHCS8-20-GR8	Hex Bolt, 1/2" x 1-1/4" Long Grade 8
4	NT8-SS	1/2" Nut, S.S.
5	TLH110-4H	TLH110-4 Wrench Head
<b>TLH113-4</b>		
1	TLH113-4P	TLH113-4 Reaction Plate
2	TLH113-4L	TLH113-4 Reaction Leg
3	HHCS8-20-GR8	Hex Bolt, 1/2" x 1-1/4" Long Grade 8
4	NT8-SS	1/2" Nut, S.S.
5	TLH113-4H	TLH113-4 Wrench Head
<b>TLH200-4</b>		
1	TLH200-4P	TLH200-4 Reaction Plate
2	TLH200-4L	TLH200-4 Reaction Leg
3	HHCS8-20-GR8	Hex Bolt, 1/2" x 1-1/4" Long Grade 8
4	NT8-SS	1/2" Nut, S.S.
5	TLH200-4H	TLH200-4 Wrench Head

**Table 2**

**Parts List - Series 150-4 Pawl Carrier Assembly**      - - see figure 3

Item#	Part#	Description
6	B94067	4" Thinline Pawl Carrier
7	A94144	4" Thinline Pawl
8	RP2-12	1/8" x 3/4" Roll Pin
9	13B020GE/S	Pawl Spring
10	A87059	Clevis Spring
11	SHCS4-8	1/4" x 1/2" Socket Head Cap Screw
12	LW4-SS	1/4" Lock Washer
13	RP2-16	1/8" X 1" Roll Pin

**Table 3**

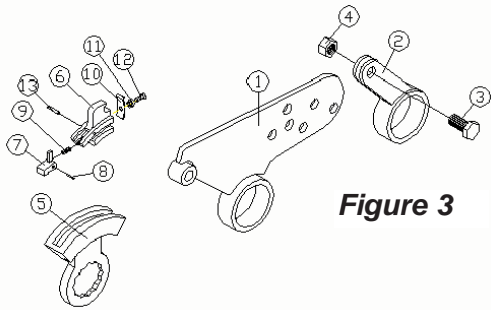
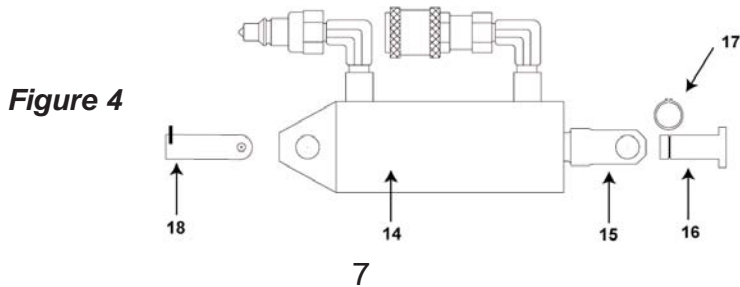

**Figure 3**

**Series 150-4 Cylinder and Parts**      - - see figure 4

Item#	Part#	Description
14	Series 150-4 Cylinder	
15	A90032	Clevis
16	A95112	Clevis Pin
17	ESR-0.375	Snap Ring
18	SP8-32	Speed Pin
	HCSK150	Seal Kit (not shown - internal)

**Table 4**



**Figure 4**

## Section 1 - Standard Flanges Assembly

1. Select the correct Auto-Torq™ Thinline wrench and reaction unit for the corresponding nut size.
2. Identify the bolt pattern as an API or ANSI standard.
3. Use the layouts supplied with this manual for the appropriate flange designation. *Figure 5* is a **SAMPLE LAYOUT**.

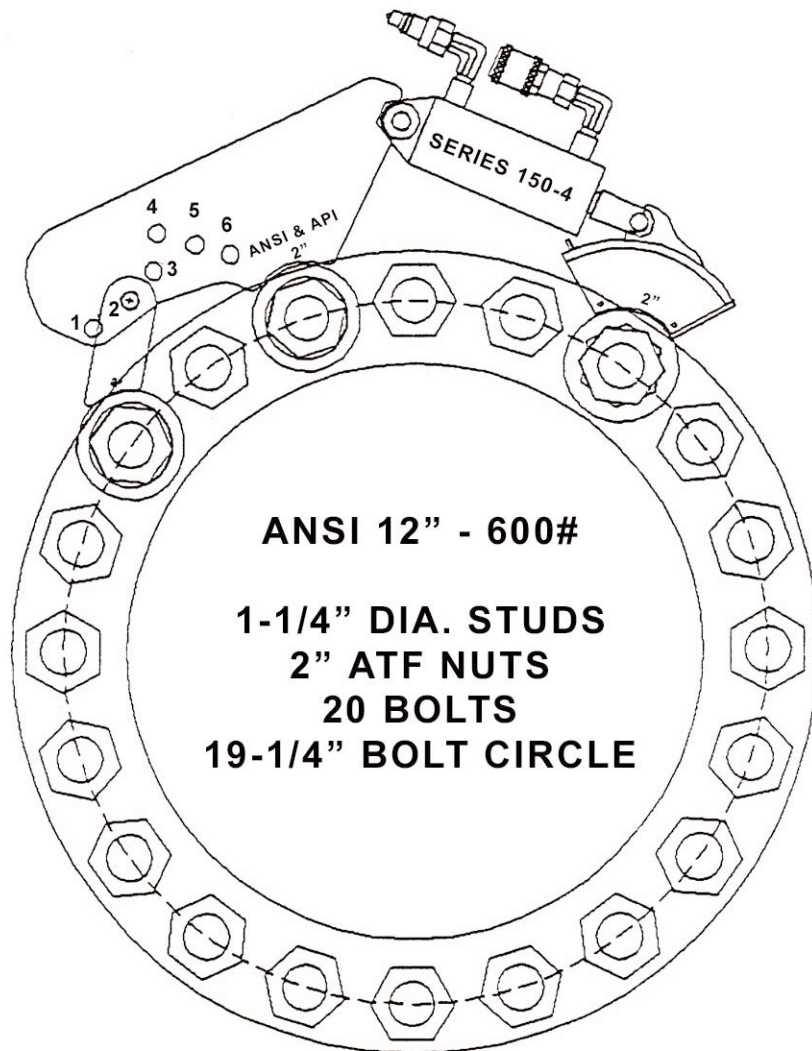

**Figure 5**

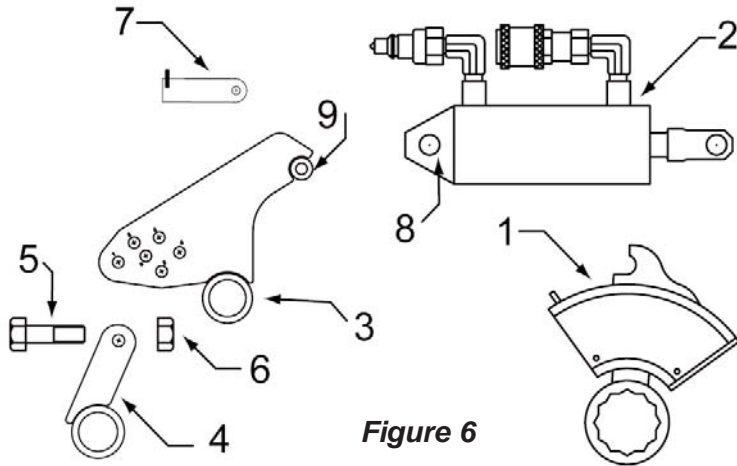
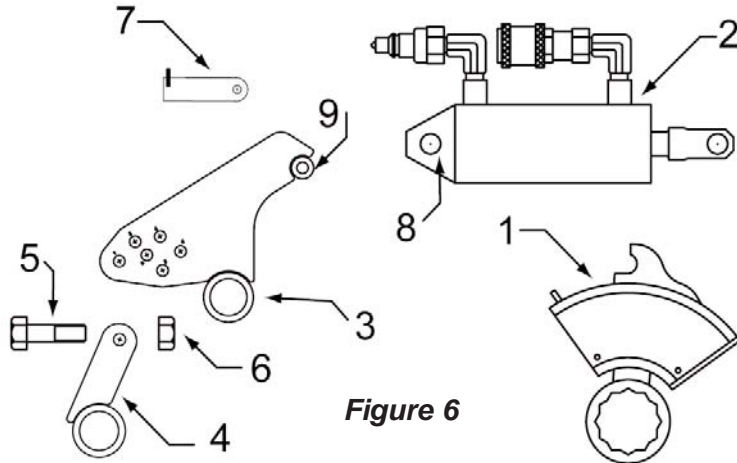

**Figure 6**

4. Refer to *Figure 6* during assembly.
5. Insert the bolt (5) through the hole in the reaction leg (4) and the corresponding hole in the reaction plate (3) as shown in the layout (*figure 4* is a sample layout) for that flange and tighten the nut (6).
6. Insert the pin (7) through the back clevis (8) of the hydraulic cylinder (2) and the clevis ring (9) on the reaction plate (3).
7. Place the reaction unit (3 & 4) and the wrench head (1) on the flange in the arrangement shown in the corresponding layout (*Figure 5*) for the flange. Take note of the number of bolts between the wrench head and the ring of the reaction plate, and between the rings of the reaction plate and reaction leg.
8. Connect the wrench to a power unit using hydraulic hoses. The pressure line of the power unit should be connected to the male quick disconnect of the wrench, while the return line should be connected to the female quick disconnect.
9. Proceed to the operation section of the manual.

## Section 2 - Non-Standard Flanges Assembly

1. Select the correct Auto-Torq™ Thinline wrench and reaction unit for the corresponding nut size.
2. Refer to *Figure 6* during assembly.



**Figure 6**

3. Compare the bolt circle diameter and number of bolts in the flange, on which you are working, with the standard flange layouts provided. If you identify a standard which matches your flange, use that set-up.
4. Insert the pin (7) through the back clevis (8) of the hydraulic cylinder (2) and the clevis ring (9) on the reaction plate (3). Refer to Figure 6.
5. Measure the distance (A) of the wrench arm. This distance is 4" on a Series 150-4 (*Figure 7*).

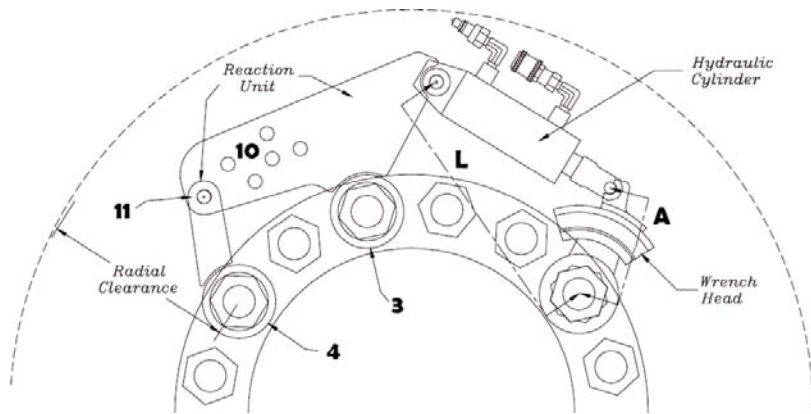

**Figure 7**

6. When the wrench and reaction unit are properly placed on the flange, the distance (L) from the center of the pin in the back clevis of the cylinder to the center of the bolt being turned should always be 9-1/16" on a SERIES 150-4.
7. Place the wrench head (1) on any bolt on the flange.
8. Place the ring of the reaction plate (3) around the bolt which would satisfy the following criteria:
  - a. The distance (L) should be correct.
  - b. The wrench head (1) should be able to rotate 60° without interfering with an adjacent bolt.
  - c. The bolt has to turn clockwise when the cylinder extends if tightening, OR counter-clockwise if loosening.
9. Place the ring on the reaction plate (3) around the bolt which would result in the proper set-up.

10. Place the ring of the reaction leg (4) around the bolt which would allow the hole (11) on the leg to align with any hole (10) on the plate. Insert the bolt (5) through the two holes and tighten the nut (6). See *Figure 7*.

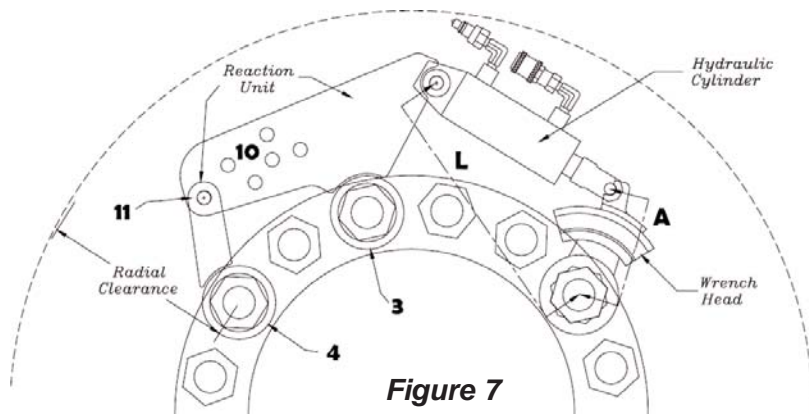

NOTE: If it is impossible to match the hole of the reaction leg with the hole on the reaction plate while keeping the proper set up, mark the reaction plate through the center of the hole in the leg and drill a hole in the plate at that point, equal in diameter to the hole in the leg.

11. Connect the wrench to a power unit using hydraulic hoses. The pressure line of the power unit should be connected to the male quick disconnect, while the return line should be connected to the female quick disconnect.

12. Proceed to the operation section of the manual.

# Operation

## Tightening

1. Select the hydraulic pressure necessary to deliver the required torque from the "Pressure VS Torque" chart. (*Page 16*)
2. Fully extend the cylinder using the Advance button on the remote control of the hydraulic power unit. Hold the button down while adjusting the pressure control knob on the power unit until the desired reading is shown on the pressure gauge. Retract the cylinder using the Retract button on the remote control.
3. Make sure that all the nuts to be tightened are at least hand tight. Failure to do so will cause the torquing operation to take longer.
4. Raise the pawl in the wrench head using the pawl control lever.
5. Slide the pawl carrier and pawl forward in the wrench head to the first position.
6. Release the pawl control lever to allow the pawl to engage the wrench head.
7. Position the wrench on the first bolt to be tightened using the setup determined previously.
8. Engage the pin in the front clevis of the cylinder in the pawl carrier.
9. Advance and retract the cylinder using the remote control buttons of the hydraulic pump.

NOTE: The pawl and pawl carrier will retract with the cylinder and engage another tooth. Three strokes are required in the 150-4 Series.

10. The pin in the front clevis of the cylinder will pull away from the pawl carrier on the last stroke of a cycle. When this occurs, remove the wrench from the bolt and rotate it backward and repeat steps 4 through 9.

11. Repeat steps 8 through 10 until the cylinder stops advancing. This will occur when the pre-set pressure (torque) is reached.

12. Repeat steps 4 through 11 for every bolt.

**NOTE:** It is always recommended to use bolting procedures when tightening bolts. FASTORQ offers bolting technology through its service division. *Table 5* on *Page 17* contains estimated torque values.

For further information call a FASTORQ representative at 281-449-6466 OR 800-231-1075.

### **Loosening**

1. Select the hydraulic pressure necessary, to deliver enough torque to break the bolts loose using the "Pressure vs Torque" chart on *Page 16*.

2. Fully advance the cylinder using the Advance button on the remote control of the hydraulic power unit. Hold the button down while adjusting the pressure control knob on the power unit until the desired reading is shown on the pressure gauge. Retract the cylinder using the Retract button on the remote control.

3. Raise the pawl in the wrench head using the pawl control lever.

4. Slide the pawl carrier and pawl forward in the wrench head to the first position.

5. Release the pawl control lever to allow the pawl to engage the wrench head.
6. Position the wrench on the first bolt to be loosened using the set-up previously determined. The wrench will hold itself as pressure is building up, but it will loosen as pressure is released.
7. Engage the pin in the front clevis of the cylinder in the pawl carrier.
8. Advance and retract the cylinder using the remote control buttons of the hydraulic pump.
9. The pin in the front clevis of the cylinder will pull away from the pawl carrier on the last stroke of a cycle. When this occurs, remove the wrench from the bolt and rotate it backward and repeat steps 3 through 8.
10. Repeat step 9 until the bolt is loose.
11. Repeat steps 3 through 10 for every bolt.

Pressure vs Torque Chart		TLH150-4	Table 5
Pressure (psi)	Torque (ft-lbs)	Pressure (psi)	Torque (ft-lbs)
100	59	2900	1,708
200	118	3000	1,767
300	117	3100	1,826
400	236	3200	1,885
500	295	3300	1,944
600	353	3400	2,003
700	412	3500	2,062
800	471	3600	2,121
900	530	3700	2,179
1000	589	3800	2,238
1100	648	3900	2,297
1200	707	4000	2,356
1300	766	4100	2,415
1400	825	4200	2,474
1500	884	4300	2,533
1600	942	4400	2,592
1700	1,000	4500	2,651
1800	1,060	4600	2,710
1900	1,119	4700	2,769
2000	1,178	4800	2,827
2100	1,237	4900	2,886
2200	1,296	5000	2,945
2300	1,355	5100	3,004
2400	1,414	5200	3,063
2500	1,473	5300	3,122
2600	1,532	5400	3,181
2700	1,590	5500	3,240
2800	1,649		

## Maximum Suggested Make-Up Torque Chart

The following are estimated torque values calculated for B7 studs lubricated with Fastorq 70+ Moly Paste loaded to 50% of yield strength

Stud Diameter (in)	Nut A/F (in)	Torque (ft-lbs)
3/4"	1-1/4"	208
7/8"	1-7/16"	336
1"	1-5/8"	503
1-1/8"	1-13/16"	739
1-1/4"	2"	1,038
1-3/8"	2-3/16"	1,409
1-1/2"	2-3/8"	1,859
1-5/8"	2-9/16"	2,396
1-3/4"	2-3/4"	3,027
1-7/8"	2-15/16"	3,761
2"	3-1/8"	4,604
2-1/4"	3-1/2"	6,650
2-1/2"	3-7/8"	8,348
2-3/4"	4-1/4"	11,215
3"	4-5/8"	14,672
3-1/4"	5"	18,776
3-1/2"	5-3/8"	23,582
3-3/4"	5-3/4"	29,144
4"	6-1/8"	35,519

**Table 6**

# Troubleshooting

<b>Problem</b>	<b>Possible Causes</b>	<b>Possible Solutions</b>
The Cylinder does not extend or retract	The quick disconnects are not connected properly	Check connections
The quick disconnect will not lock, or will not release	The hydraulic hose is still pressurized	Release the pressure in the hose
The wrench locks up on the bolt	The pawl control lever is jammed	Release the pawl control lever

***Table 7***

## Storage

When storing Auto-Torq™ Thinline™ follow these steps:

1. Fully retract the cylinder.
2. Rinse and clean the wrench
3. Lubricate the entire wrench with a light film of oil

## Auto-Torq™ Thinline Wrenches

Auto-Torq™ Thinline wrenches include a wide variety of wrench sizes to fit different applications. These wrenches are available in six series, and operate on 5,500 psi of hydraulic pressure.

The table below lists the series with their corresponding range of nut sizes and torque capacity.

Thinline Series	Nut Sizes A/F (in)	Torque (ft lbs)
150-4	1-1/4 to 2	3,240
200-6	2-3/16 to 3-1/8	8,640
250-9	3-1/2 to 4-5/8	20,250
325-12	4-1/4 to 5-3/8	41,840

**Table 8**

## Limited Warranty

FASTORQ® warrants its products against defects in workmanship and materials for 180 days from date of delivery to customer. Warranty does not cover ordinary wear and tear, abuse, misuse, overloading or altered products.



### **FASTORQ**

18914 East Industrial Parkway  
New Caney, TX 77357

T: 281-449-6499

TF: 800-231-1075

Fax: 281-572-1329

Email: [sales@fastorq.com](mailto:sales@fastorq.com)

Website: [fastorq.com](http://fastorq.com)