

## ZIP-LIFT™ Robotic Load Connector / Crane Grapple

The **problem** of deploying and retrieving equipment such as well heads and blowout preventers in an underwater environment has become greater as exploration and production programs are carried out in ever greater water depths.

If a blowout preventer is accidentally separated from a drilling riser in water depth greater than 1000 feet; a system is required to robotically connect lifting lines from the surface to pad eyes on the BOP. The connection must be made using ROV capabilities.

If a well head loses power on the sea bottom; a system is required to robotically connect lines to the collet rods so the well head may be released from the well and lifted to the surface.

Standard clevis and pin arrangements are very difficult for an ROV to connect to a pad eye and impossible to connect to a threaded collet rod. A system is required that connects lines to collet rods or threaded lifting eyes using ROV manipulators.

The **solution** to the problem is the Zip-Lift™ Robotic Load Connector with a female threaded connector that pushes on to a male threaded rod without needing rotation. The connector closes on the male threads and will not release until the load is set down with slack in the line and the release mechanism is actuated.

Figure 1 shows a photo of the 60 ton Zip-Lift™ Robotic Load Connector.

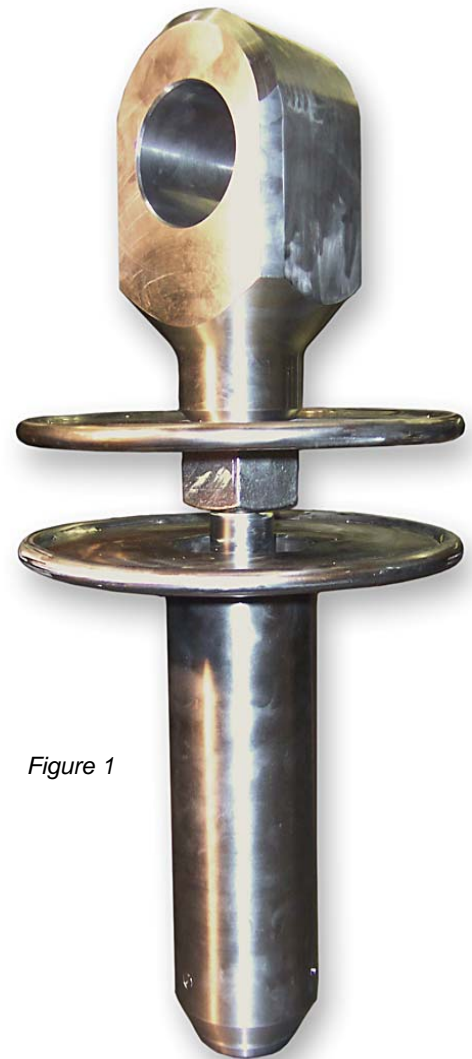

*Figure 1*

Figure 2 is a cross section of this connector with the female thread segments (A) in the open position and pushed over the male threaded rod (B).

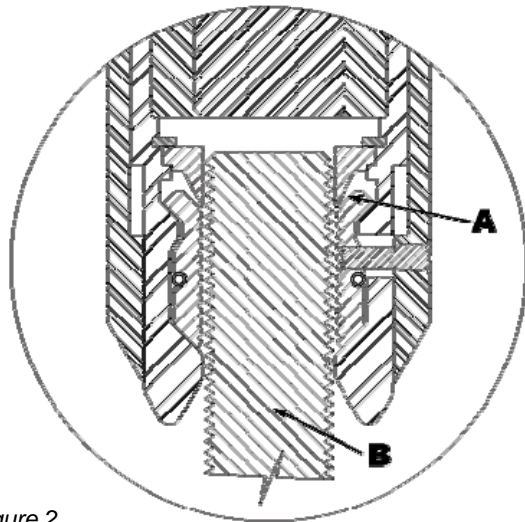

Figure 2

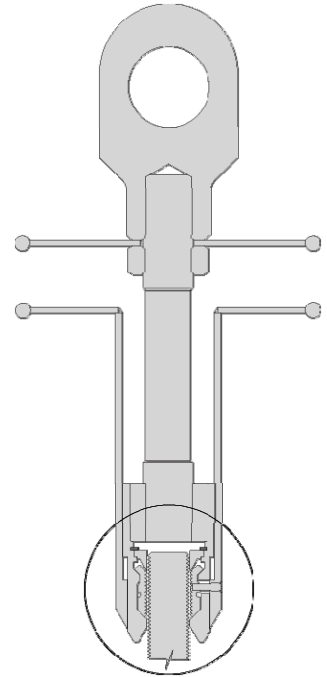

Figure 3 is a cross section showing the female thread segments (A) closed on the male threaded rod (B). The female thread segments close on the male threaded rod as the segments engage the internal taper of the housing (C) as load is applied to the rod (B). A coiled garter spring (D) urges the segments into engagement.

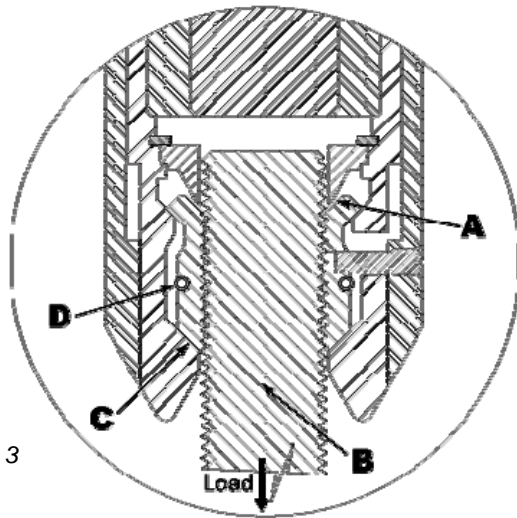
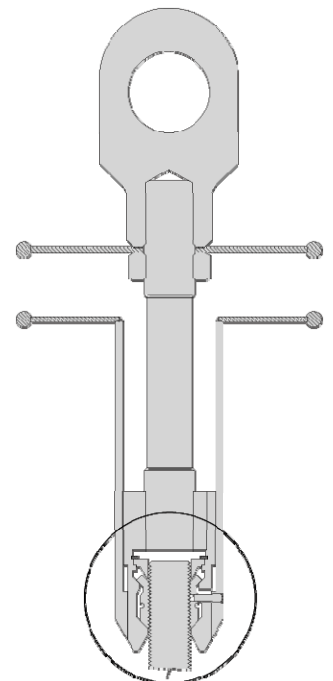

Figure 3



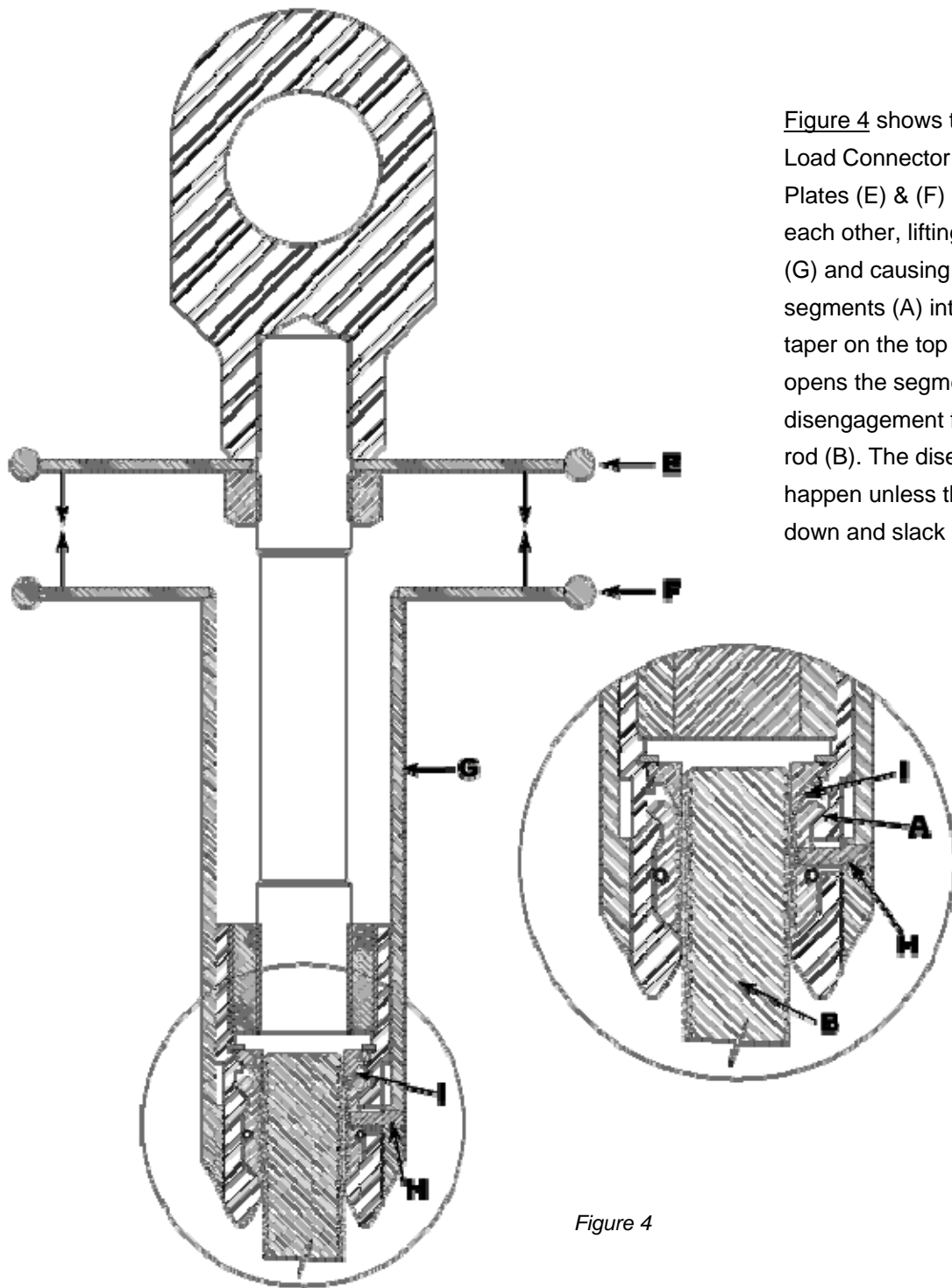

Figure 4 shows the Zip-Lift™ Robotic Load Connector in the *open* position. Plates (E) & (F) are squeezed toward each other, lifting the outer housing (G) and causing the pins(H) to lift the segments (A) into contact with the taper on the top cap (I). This motion opens the segments (A) and allows disengagement from the threaded rod (B). The disengagement cannot happen unless the load has been set down and slack put in the line.

Figure 4

The innovation is the push on/ pull off segmented female thread connector that engages and disengages a standard male thread without rotating and has the strength to support the full tensile strength of the male thread of the same material.

This design allows the sub sea use of tools such as the Zip-Lift™ Robotic Load Connector as well as stud tensioners, flange pullers and any device that requires robotic engagement and disengagement. This opens new markets for our tools.

Exploration and production companies and their contractors gain the capability to deploy and retrieve valuable assets from the sea floor even when primary systems fail.